



MINORS DIVISION

GENERAL RULES

1. PLAYER ELIGIBILITY/GRADE

- 1.1. A player's grade is determined by the player's **CURRENT grade upon registration.**
- 1.2. For MINORS, players are currently either in the fifth or sixth grade upon registering.

2. PLAYERS AND POSITIONS

- 2.1. A minimum of seven (7) players is needed to start a game or a forfeit will result.
- 2.2. Defensive Players: In the MINORS Division, teams will field (9) defensive players (3 outfielders, 4 infielders, a pitcher and a catcher)

3. FIELD AND GROUND RULES

- 3.1. Where not covered by specific Twinsburg Baseball League Inc. amendments, Official Baseball Rules will apply.
- 3.2. The HOME team will prepare the field for play and will practice 30 minutes before the game. The visitors will practice 15 minutes before the game and will put the bases away at the end of the game. Both teams will clean their respective areas and share in the cleaning of common areas after the game.
- 3.3. Only officially registered team members may participate. **NO EXCEPTIONS.**
- 3.4. All team members in attendance will play. Disciplinary actions will be allowable as long as competing coach is advised before the game.
- 3.5. Three outs made in the field (strikeouts included) will constitute an inning.
- 3.6. Substitution Rule
 - 3.6.1. The free and unlimited substitution of defensive players is permitted except for pitchers, but the batting order shall remain the same. Once a pitcher is removed from the mound he cannot return to pitch in that game or in the completion of a suspended game, although he may play any other position.
 - 3.6.2. Each player must play a minimum of two (2) FULL innings before the end of the 4th inning.
PENALTY: Any team that violates Rule 3.6 will forfeit the game in question.
- 3.7. It will be the home team's responsibility to maintain the official score. Once the score has been agreed upon by both coaches, the head coach will be responsible for providing the score to scores@twinsburgbaseball.com, or logging on and entering it themselves on the website.
- 3.8. It will be the commissioner responsibility to maintain division standings to seed playoff brackets.

4. PITCHING

- 4.1. TBL follows the MLB Pitch Smart pitch count limits and required rest recommendations.
- 4.2. One coach or parent from each team is responsible for keeping track of pitch counts for all pitchers. It is encouraged for coaches to confer on pitch count totals for players approaching daily limits.
- 4.3. A pitcher may exceed the daily pitch count limit to finish an at bat, but may not face a new hitter once the daily limit is exceeded.
- 4.4. No pitcher may exceed 85 pitches in any one day.
- 4.5. Throwing one pitch in a game constitutes a pitching appearance.
- 4.6. On 0 full days of rest between appearances, pitchers may not exceed 20 pitches.
- 4.7. On 1 full day of rest between appearances, pitchers may not exceed 35 pitches.
- 4.8. On 2 full days of rest between appearances, pitchers may not exceed 50 pitches.
- 4.9. On 3 full days of rest between appearances, pitchers may not exceed 65 pitches.
- 4.10. The full MLB Pitch Smart Guidelines can be found at <http://m.mlb.com/pitchsmart/pitching-guidelines>.

5. BATTING

- 5.1. Teams will bat all players on their roster in a predetermined order, a copy of which will be provided to the opposing team. Late arrivals will be placed at the bottom of the order.
 - 5.1.1. Each player of the offensive team shall bat in the order that his name appears in his team's batting order.
 - 5.1.2. The first batter in each inning after the first inning shall be the player whose name follows that of the last player who legally completed his time at bat in the preceding inning.
 - 5.1.3. A batter shall be called out, on appeal, when he fails to bat in proper turn, and another batter completes a time at bat in his place.

5.1.3.1. The proper batter may take his place in the batter's box at any time before the improper batter becomes a runner or is put out, and any balls and strikes shall **e o u t e d i n t h e p r o p e r b a t t e r ' s t i m e** at bat.

5.1.4. When an improper batter becomes a runner or is put out, and the defensive team appeals to the umpire before the first pitch to the next batter of either team, or before any play or attempted play, the umpire shall (1) declare the proper batter out; and

(2) nullify any advance or score made because of a ball batted by the improper batter or because of the improper batter's advance to first base on a hit, an error, a base on balls, a hit batter or otherwise.

NOTE: If a runner advances, while the improper batter is at bat, on a stolen base, wild pitch or passed ball, such advance is legal.

5.1.5. When an improper batter becomes a runner or is put out, and a pitch is made to the next batter of either team before an appeal is made, the improper batter thereby becomes the proper batter, and the results of his time at bat become legal.

5.1.6. When the proper batter is called out because he has failed to bat in turn, the next batter shall be the batter whose name follows that of the proper batter thus called out.

5.1.7. When an improper batter becomes a proper batter because no appeal is made before the next pitch, the next batter shall be the batter whose name follows that of such legalized improper batter. The instant an improper batter's **a t t e m p t s a r e l e g a l i z e d**, the batting order picks up with the name following that of the legalized improper batter

5.2. A batter is out when –

5.2.1. His fair or foul fly ball (other than a foul tip) is legally caught by a fielder.

5.2.2. When a third strike is caught or not caught by the catcher.

5.2.3. He bunts foul on third strike.

5.2.4. An Infield Fly is declared.

5.2.5. He attempts to hit a third strike and the ball touches him.

5.2.6. His fair ball touches him before touching a fielder.

5.2.7. A third strike foul-tip is legally caught by the catcher.

5.3. The batter becomes a runner when he hits a fair ball.

5.4. Bunting is permitted.

6. BASE RUNNING

6.1. Leading off is not permitted. Runners may not leave a base until the ball is released from the pitcher's hand. Once the pitcher starts in motion he/she must deliver a pitch to home plate. If caught leaving the base early, runners will be warned and be forced to return to the previous base. All subsequent instances of runners leaving early will result in the player being called out.

6.2. If a team is up by 5 runs or more, stealing a base by the winning team is no longer permitted until the deficit is 4 runs or less. In the final designated inning (7th inning or if the umpire declares a final inning due to time limit) if a team is up by 8 runs or more, stealing a base by the winning team is no longer permitted until the deficit is 7 runs or less. No advancement of any kind on non batted balls is allowed by a team winning by 5 or more runs or 8 or more runs in the final inning, even on passed balls. Running on passed balls is defined as a steal for the purposes of these rules. When leading by an amount that triggers this "no stealing" rule, non-batted pitched balls are dead when they cross home plate, meaning catchers cannot attempt to throw out or throw behind base runners with a large lead.

6.3. Runners may tag up at their own risk on any fly ball, fair or foul, once the ball is caught.

6.4. Runners who inadvertently turn toward second after reaching first cannot be tagged out **u n l e s s t h e u m p i r e ' s j u d g e t h e s h o** intent to reach second base.

6.5. Infield fly rule will apply.

6.6. A runner must slide, or give up, or attempt to avoid being tagged while a play is being made on him. No runner will initiate any contact with another player.

PENALTY: The runner is out, and if the umpire deems such contact is deemed to be flagrant, the offending player will be ejected.

6.7. On a force play, the runner shall slide on the ground in a direct line between the two bases, or away from the fielder, to avoid making contact with, or altering the play of, the fielder.

PENALTY: With less than two outs, the runner is declared out as well as the batter-runner. Runners shall be returned to the bases they occupied at the time of the pitch. With two outs, the runner shall be declared out and the batter-runner credited with a fielder's choice. Violations result in outs; flagrant violations will result in ejection.

6.8. In the event of an injury, a courtesy runner will be permitted. That runner will be the last player who was called out.

6.9. Runners may advance one (1) base on an overthrow out of play which is determined to be past the bench. It will still be at discretion of the umpire.

7. RUN LIMIT/MERCY RULE

TBL
Minors
Rules
Revised:
February
2016

- 7.1. There is NO run limit per inning.
- 7.2. **MERCY RULE** - If the losing team is behind by 15 or more runs after the fourth inning, or 10 or more runs after the fifth inning, the game is over.

8. THE PLAYING FIELD AND EQUIPMENT

- 8.1. Bases: The infield shall be 70-foot square (LLB).
- 8.2. **Pitcher's Mound: The distance between the front side of the pitcher's plate and home base the rear point of home plate)** shall be 50 feet (LLB).
- 8.3. Complete and proper equipment (by position) must be worn at all times. All male players should wear athletic supporters. **Male catchers must wear cups**, females appropriate chest protection.
- 8.4. Metal cleats are not permitted.
- 8.5. Bats may not exceed 2 3/4 inches in diameter and may not exceed 33 inches in length. Non-wood bats shall be labeled with a BPF (bat performance factor) of 1.15 or less. Wood bats are permitted.
- 8.6. All offensive players must wear batting helmets while outside the dugout. Runners who intentionally remove their helmets while on the base paths will be called out.
- 8.7. All players will wear complete uniforms as issued by the league including baseball pants (not issued).
- 8.8. No shorts will be permitted.
- 8.9. All on-field coaches must also be in uniform.

9. BASE COACHES

- 9.1. The offensive team shall station two (2) base coaches on the field during its time at bat, one at 1B and one near 3B.
- 9.2. Base coaches shall be an adult manager or coach.
- 9.3. Base coaches shall:
 - 9.3.1. **Remain within the base coaches' zone at all times, except when necessary to provide space for a defensive player to make a play on a batted or thrown ball.**
 - 9.3.2. Talk to members of their own team.
 - 9.3.3. **A offensive dugout shall be removed from the base coaches' zone.**

10. UMPIRES

- 10.1. The decision of the umpire is final. Any umpire's decision which involves judgment, such as, but not limited to, whether a batted ball is fair or foul, whether a pitch is a strike or a ball, or whether a runner is safe or out, is final.
- 10.2. No player, manager, coach or substitute shall object to any such judgment decisions.
- 10.3. Only a head coach or designated speaking coach may discuss plays with the umpire. The "designated speaking coach" shall be the **team's** representative during the pre-game conference with the umpiring crew.
- 10.4. In the event of an injury the umpire is to immediately call time. Any game related injury must be reported within 24 hours of the occurrence. Injury forms can be obtained at the concession stand.

11. COACH, PLAYER AND SPECTATOR CONDUCT

- 11.1. Head coaches must be at all times, examples of good sportsmanship.
- 11.2. The head coaches are responsible for the conduct of their players and assistant coaches.
- 11.3. Head coaches shall, to the best of their ability, control the conduct of parents and spectators on their side of the field, making every reasonable effort to discourage any type of harassment of umpires and opposing players, coaches, and fans.
- 11.4. No manager, player, substitute, coach, trainer or bat boy shall at any time, whether from the bench, the coach's box or on the playing field, or elsewhere:
 - 11.4.1. Incite, or try to incite, by word or sign a demonstration by spectators.
 - 11.4.2. Use language which will in any manner refer to or reflect upon opposing players, a coach, an umpire, or any spectator.

11.4.3. Call "Time," or employ any other word or phrase or commit any act while the ball is alive and in play for the obvious purpose of trying to make the pitcher commit a balk or to try to distract the pitcher in their pitching motion.

11.4.4. Make intentional contact with any player, coach, umpire or spectator.

11.4.5. Take a position in the batter's line of vision, and with deliberate unsportsmanlike intent, act in a manner to distract the batter. **PENALTY:** The offender shall be removed from the game and shall leave the playing field, and, if a balk is made, it shall be nullified

TBL
Minors
Rules
Revised:
February
2016

11.5. No coach or staff member will appear at any game or practice under the influence of alcohol or controlled substance.

11.6. Smoking and/or the use of any and all tobacco products is prohibited on the playing field and in the bench area.

11.7. Coaches are not to leave the field or bench area for the purpose of smoking.

PENALTY: IMMEDIATE REMOVAL FROM THE LEAGUE for any coach, staff member and/or individual that violates Rules 10.4, 10.5, and/or 10.6.

11.8. All players must remain inside their respective dugouts unless fielding, batting, warming up, or on deck. Warning given for first offense.

An out will be assessed for any further offense. Coaches may not stand behind the backstop.

11.8.1. **EXCEPTION** - A batter may be "on deck" only when accompanied by a manager, other adult coach, or parent who may assist. Only one batter may be "on deck" at a time. A batter may not be "on deck" directly behind the backstop. It will be the responsibility of the adult accompanying the batter to ensure the batter is not presenting a safety risk to others, and that the batter is sufficiently clear of the playing field so as not to be at risk of injury from a batted/thrown ball.

11.8.2. **EXCEPTION** - A pitcher may warm-up prior to entrance into a game only when accompanied by a manager, other adult coach, or parent who may assist. Only one pitcher may warm-up at a time. It will be the responsibility of the adult accompanying the pitcher to ensure the pitcher is not presenting a safety risk to others, and that the pitcher is sufficiently clear of the playing field so as not to be at risk of injury from a batted/thrown ball.

11.9. Other than as defined in the **BASE COACHES** section of these rules, and the two exceptions noted in 10.8, above, all coaches are to remain in the dugout. A warning will be issued for the first offense. An ejection will be issued for any further offenses.

11.10. There will be no throwing of equipment such as helmets and bats. It will be in umpires' judgment to issue a warning and an out or an ejection for any infraction. If the third out has been completed, the out will be applied to the next inning. For the second offense, an out and ejection of thrower. For unintentional slipping of a bat, there will be a warning to both player and coach for first offense and an out assessed for subsequent offenses.

12. EJECTIONS

12.1. Any player or coach who is ejected from a game by an umpire is automatically suspended from the next game played, including play-off, championship and tournament games. There is no appeal.

12.2. Anyone who is ejected from a game must immediately leave the area in a sportsmanlike manner before play will resume. An assistant coach may be designated as head coach to resume play. If no other assistant is available, the umpire may designate a parent or player as head coach to resume play.

12.3. Umpires will report all ejections to the Head Umpires and division commissioner who will report it to the Officers and Trustees of Twinsburg Baseball League Inc.

12.4. Anyone ejected from two (2) games during a season must meet with the Officers and Trustees of the League who may consider suspending the individual for the remainder of the season.

13. GAME TIMES AND DURATION

13.1. All games are scheduled for seven (7) innings and will begin within ten (10) minutes of scheduled starting times unless waiting for completion of an earlier game or clearing of inclement weather.

13.2. In the event of a tie, extra innings may be played as the time limit allows.

13.3. A game that is stopped for any reason with less than three and one half (3 ½) innings completed will be a suspended game and will be resumed at a later date from the point at which it was stopped.

13.4. All games will adhere to a strict time limit of 2 hours.

13.4.1. Time will officially start on the first pitch. This should be noted by the team scorekeepers and announced to both head coaches upon the delivery of the first pitch of the game.

13.4.2. No new inning will be started after the 2 hours time limit.

13.4.2.1. An inning will be considered started after the final out of the previous inning is recorded.

13.4.3. If the score is tied after the 2 hour time limit and a new inning cannot be started, the game will be considered a tie.

13.4.4. A **Drop Dead rule** will take effect at 2 hours 30 minutes. The game will immediately end, regardless of the situation. The at-bat does not have to be completed if this occurs.

13.4.4.1. When the Drop Dead rule takes effect, if the HOME team is batting and they have scored the go-ahead run, they will be declared the winner with the current score. If the game is tied or the HOME team is behind and have not had a chance to complete their at-bat, the game will revert back to the last complete inning.

13.5. Pitchers will be given 5 warm-up pitches between innings or pitching changes. The fifth pitch will be thrown down to second and then

BATTER UP .

TBL
Minors
Rules
Revised:
February
2016

- 13.6. **Speed-Up-Rule** - Teams may elect to use a courtesy runner for the catcher of the upcoming inning (after two outs). The replacement runner must be the batter that made the last out. The sole purpose should be to speed up the start of the next inning. The player must be the catcher for the next inning.
- 13.7. Umpires have, at their discretion (after a mutual agreement), the option to stop a game because of darkness, even if the game has not reached its targeted number of innings played or time slot allowance. For games meeting the minimum number of innings needed (3 ½), the Drop Dead rule (13.4.4.1) will be utilized to determine the outcome of the game. Otherwise the game will be treated as a suspended game (13.3).

14. PROTESTS

- 14.1. No protest will be heard, except in regard to violations of the Pitching rules defined herein.
- 14.2. Only the head coach or acting head coach may file protest.
- 14.3. Protests shall be made as follows:
- 14.3.1. The protesting head coach shall immediately, and before any succeeding play begins, notify the umpire that his team is playing the game under protest.
 - 14.3.2. Within 48 hours, a formal protest must be submitted in writing to the Head Umpire, who will evaluate the validity of the protest and submit it to the Officers and Trustees of the League.
 - 14.3.3. The written protest must be accompanied by a Twenty-five dollar (\$25) cash deposit to be considered valid. The deposit will be returned only if the protest is upheld.
 - 14.3.4. All valid protests will receive a hearing with the division commissioner, the Head Umpire and the Officers and Trustees of the League.

15. PROCEDURES

15.1. Lightning and Inclement Weather Policy (OHSAA Policy)

- 15.1.1. **Recognition** - Coaches, athletic trainers, athletes, administrators, commissioners and contest officials shall be educated regarding the signs indicating thunderstorm development. Since the average distance between successive lightning flashes is approximately two to three miles, ANYTIME that lightning can be seen or heard, the risk is already present. Weather can be monitored using the following methods:
- 15.1.1.1. **Monitor Weather Patterns** – Be aware of potential thunderstorms by monitoring local weather forecasts the day before and morning of the competition, and by scanning the sky for signs of potential thunderstorm activity.
 - 15.1.1.2. **National Weather Service** – Weather can also be monitored using small, portable weather radios from the NWS. The NWS uses a system of severe storm watches and warnings. A watch indicates conditions are favorable for severe weather to develop in an area; a warning indicates severe weather has been reported in an area, and everyone should take proper precautions. Any thunderstorm poses a risk of injury or death even if it does not meet the criteria for severe weather. Therefore, anytime thunderstorms are in the forecast (even if it is only a 20 percent chance), event organizers shall be at a heightened level of awareness to the potential danger of lightning.
- 15.1.2. **Evacuation** – If lightning is imminent or a thunderstorm is approaching, all personnel, athletes and spectators shall evacuate to available safe structures or shelters. A list of the closest safe structures should be announced and displayed on placards at all athletic venues.
- 15.1.3. **THIRTY-MINUTE RULE** – Competition or practice shall be suspended once lightning has been recognized or thunder is heard. It is required to wait at least 30 minutes after the last flash of lightning is witnessed or thunder is heard prior to resuming practice or competition. Given the average rates of thunderstorm travel, the storm should move 10-12 miles away from the area. This significantly reduces the risk of local lightning flashes. **Any subsequent lightning or thunder after the beginning of the 30-minute count shall reset the clock, and another count shall begin.**

15.2. General Weather/Rainouts Guidelines

- 15.2.1. It is our standard practice to call games on account of weather AT THE FIELD.
- 15.2.2. Therefore, all players, coaches and parents are expected to go to their appointed field at the appropriate time for their game, regardless of weather condition.

- 15.2.3. If conditions permit, we will make every attempt to get scheduled games played.
- 15.2.4. If conditions do not permit, the game will be cancelled and rescheduled.
- 15.2.5. Occasionally, games will be cancelled in advance if a check of the fields determines that it/they are unplayable. Also, if conditions are poor for an extended period during the day on a game day, we will attempt to cancel the game(s) in advance.
- 15.2.6. When in doubt, show up at the field.

TBL
Minors
Rules
Revised:
February
2016

15.3. Cancelled Games

15.3.1. If your game is cancelled either beforehand or during the game (lightning, rain, unplayable field, etc.), please notify your Commissioner as soon as possible.

15.3.2. The Commissioner will coordinate rescheduling your game.

15.4. Communications

15.4.1. During the season, please contact your Commissioner with ANY questions you may have. The Commissioners attend weekly board meetings during the season and are update on virtually all issues.

15.4.2. If you cannot contact your Commissioner, please contact the Trustee responsible for Coaches and Commissioners.

15.5. Playoffs

15.5.1. Playoffs will be held at the end of the season for Coach Pitch II, Juniors, Minors and Majors divisions. Commissioners are responsible for seeding the tournament based on won-lost records (win percentage) of each team.

15.5.2. Commissioners reserve the right to tweak pitching rules for playoffs.

15.5.3. The winning coach of each game is responsible for notifying the Commissioner of the outcome of each game.

15.6. End of Season Activities

15.6.1. Picnics

15.6.1.1. The TBL finishes the season in late June/early July with several different activities for the different divisions.

15.6.1.2. The end of season picnic and trophy presentation for the T-ball and Coach Pitch I/II division is held at the end of June.

Please check the website (<http://www.twinsburgbaseball.com/>) for each season's planned dates.

15.6.1.3. As a coach, you are welcome to host your own end of season picnic for your team however this should not be done in lieu of attending the league picnic.

15.6.1.4. Picnics/Awards presentations for the upper divisions (Juniors, Minors, Majors) are scheduled around the championship games for each division respectively. The league does this to enhance the air of excitement around the championship games by bringing a larger crowd together to watch the game. The current season schedule can be found here - <http://www.twinsburgbaseball.com/>.

15.6.2. Playoffs

15.6.2.1. For the upper divisions (Coach Pitch II, Junior, Minors and Majors) TBL conducts a tournament at the end of the regular season, with teams seeded based on their won/loss record (winning percentage) for the regular season. The tournament is typically single elimination and culminates with a champion crowned for each division (specific division playoff format and schedule will be determined by the division commissioner).

15.6.3. All-Star Teams

15.6.3.1. Towards the end of the season, each of the upper divisions (Coach Pitch I/II, Juniors, and Minors) selects players to form two All-Star teams for their division, that will play each other in a final game.

15.6.3.2. All-Star teams are not formed for the T-ball divisions.

TBL Minors
Rules
Revised:
February 2016



MINORS DIVISION

Measuring Base paths/Pitcher's Plate

THE PLAYING FIELD

1. The infield shall be 70-foot square (LLB)
2. The distance between the front side of the pitcher's plate and the rear point of home plate shall be 50 feet (LLB).

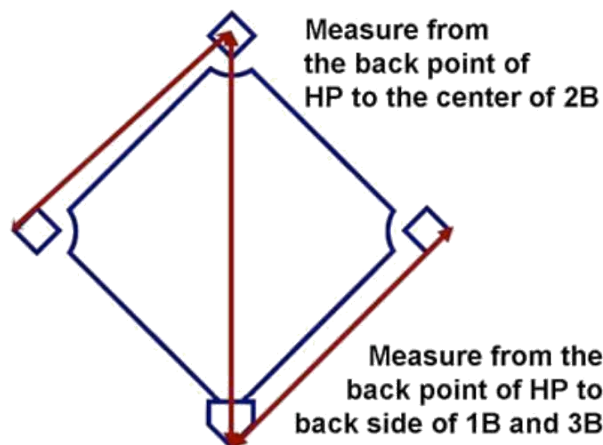
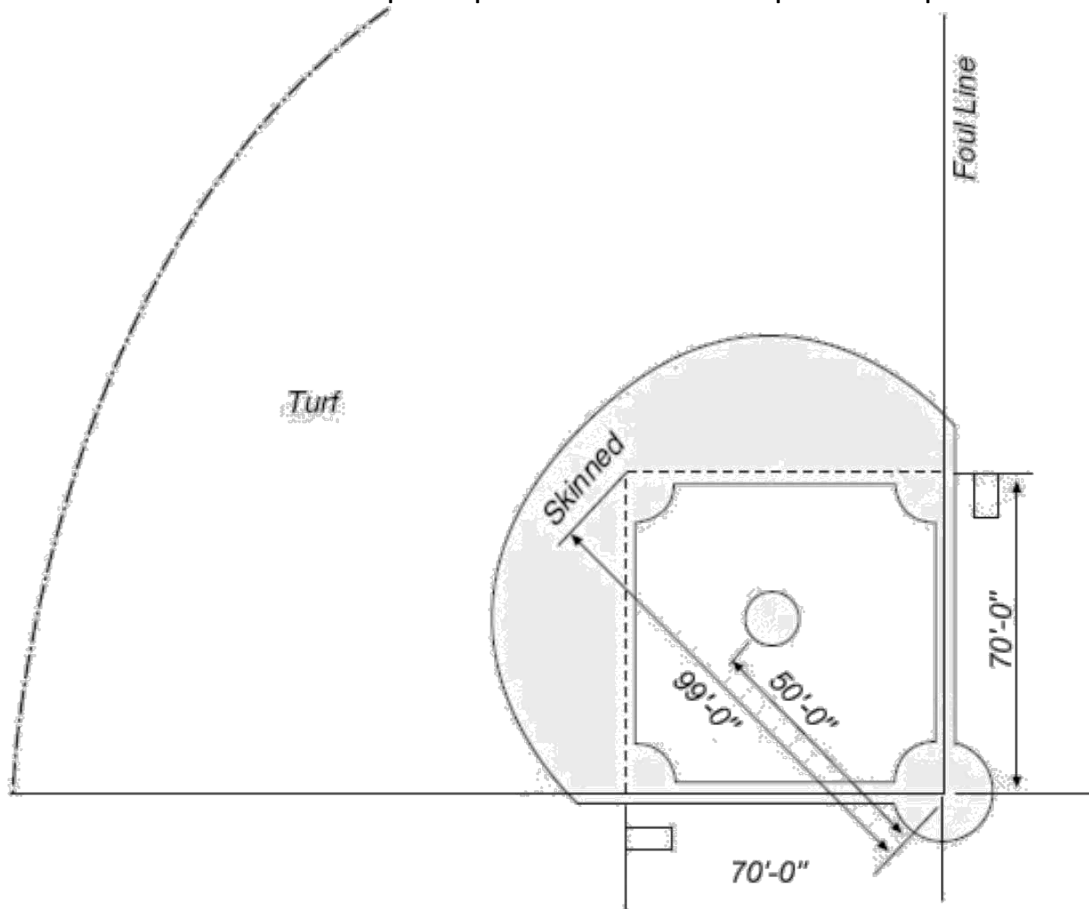

TBL
Minors
Rules

Revised: February 2016